

work

IDEAS

THE LATEST
IN BATHROOM
INSPIRATION



Cover Feature:
ZUCCHETTI / Him



WINTER
EDITION
2016

robertson®
BATHWARE
— SINCE 1987 —

ROBERTSON.CO.NZ



Pure Freude
an Wasser

BATHROOM UNDERSTATED ELEGANCE

NEW

GROHE ESSENCE

Classic lifestyle, gently interpreted. For people who are attracted by clear, visually pleasing designs, GROHE Essence brings aesthetics without pretension. Complete bathrooms in this range use balanced, modern styling and create space for inventive furnishing ideas and innovative technologies.



Discover the full GROHE Essence collection on line at **ROBERTSON.CO.NZ** or request a copy of our latest GROHE brochure.





SWING

The SWING wash basin has a soft, cut away basin design incorporated into a bold, contemporary block console.

This versatile basin can be used as either a wall hung or countertop basin and comes in 3 lengths; 85cm, 105cm and 120cm.

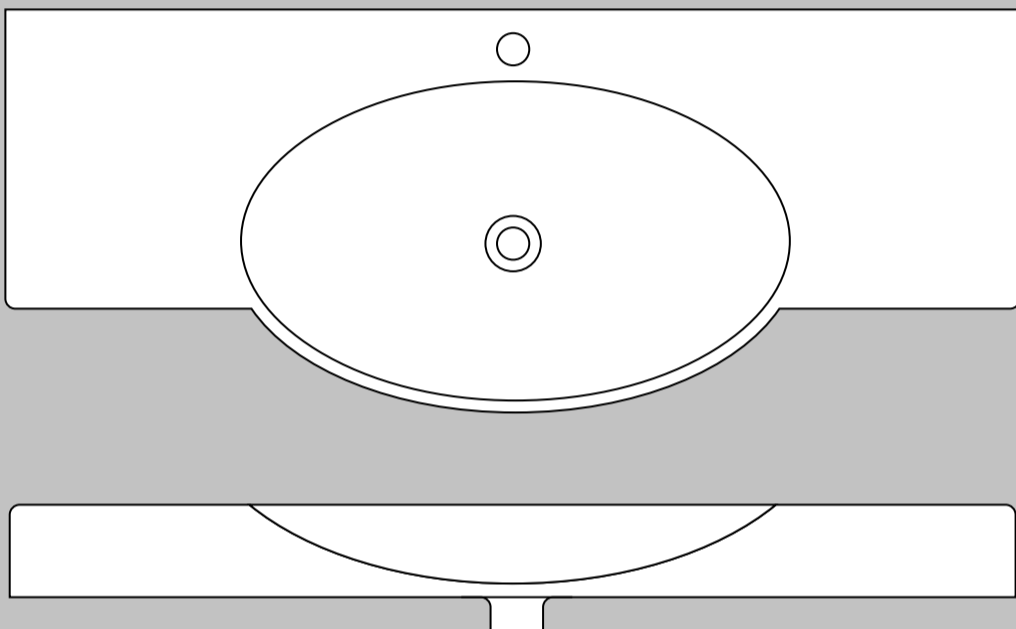

BLOCK

The thick, solid construction of the BLOCK washbasin will add minimalistic charm and modern appeal to any bathroom. The slightly rounded corners add a touch of softness while the solid perch leaves just the right amount of space for a striking modern faucet.

This striking basin comes in 2 lengths; 65cm and a 90cm option with a left aligned basin allowing for additional counter space on the right.

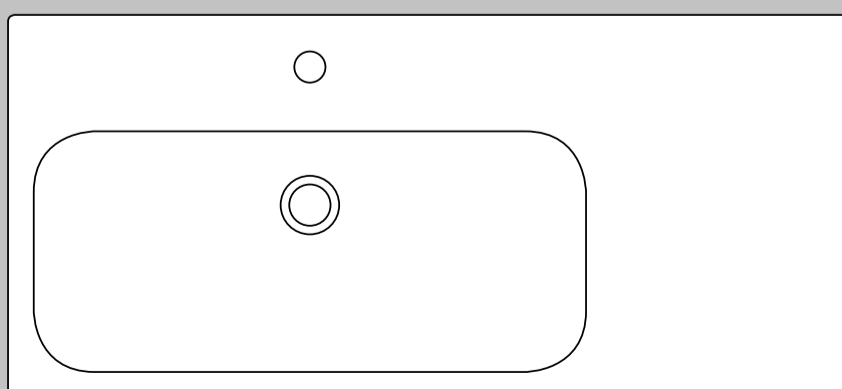

HIM

A radical object...

HIM, the latest Zucchetti collection of taps designed by Ludovica+Roberto Palomba, has a radical, compact and streamlined design. The product has a green soul: it was designed to reduce the quantity of materials used to a minimum, creating a lightweight object that allows the water to show off the full extent of its vitality.

The result of this architectural genesis, developed around the concept of 'less is more', is a simple, elegant and linear product, in harmony with the evolution in washbasins towards more subtle, geometric solutions.

Ludovica+Roberto Palomba, the creators of the collection, define HIM as "an architectural object lived in by an almost ergonomically organic handle". The designers' research started with the intention of creating a radical object, a geometry from which water springs with all its energy. The idea developed in the direction of less is more, searching for a stripped-down use of the material and a formal expression of its function.

The distinguishing feature of this collection, designed and interpreted for the whole bathroom, is the compact, streamlined design of the flat spout with its cascade jet. Zucchetti's patented concealed cartridge allowed the volume of the mixer body to be reduced to a minimum, with the cartridge inserted underneath the ceramic surface to give a marked effect of lightness, in harmony with the pure, elegant and angular shapes of the single lever mixer.



Designed by Ludovica+Roberto Palomba

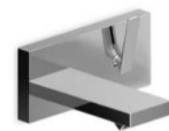
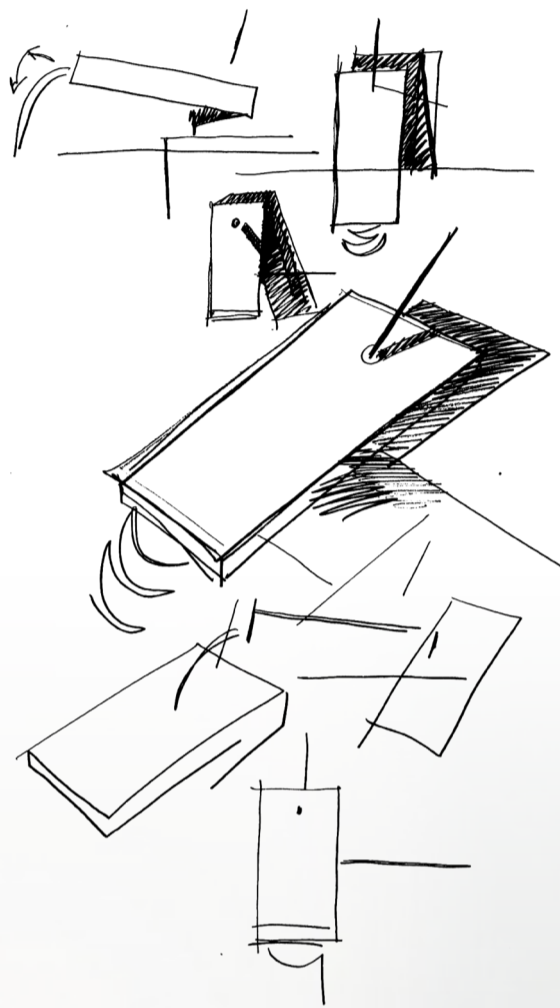

ZUCCHETTI.

 Made in Italy

Sleek detailing with a Multi Wood furniture finish

The latest addition to our bathroom furniture portfolio, the EVO collection by PARISI features cleverly crafted wall vanities coupled with contemporary mirror storage pieces. Handles are replaced with angled drawer profiles to achieve sleek detailing expertly finished in a unique and natural Multi Wood. These pieces are designed to suit any modern or traditional bathroom setting.

PARISI's vision has always been to create and curate a harmonious blend of design and quality, as well as a positive contribution to living well. PARISI's Italian supplier partners are world leaders in design, innovation and manufacturing.

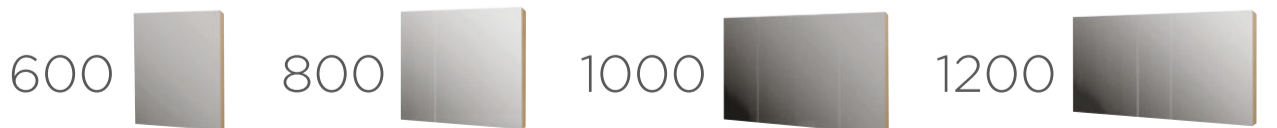

WHITE ON WHITE

The Dylan Apartments

Grey Lynn, Auckland

As Auckland establishes itself as one of the world's most liveable cities, the living requirements for its increasingly cosmopolitan population are becoming more sophisticated.

Style, personality, and astute design. Enduring materials and great architecture. The Dylan apartments have it all, with a particular focus on the requirements of a discerning resident.

Bathrooms are often utilitarian, and to rise above this fastidious attention to detail, like hand selecting the best fixtures and fittings, has ensured that a refined bathing experience can be celebrated.

Bathroom fittings include beautiful matt white ZUCCHETTI Pan tapware from Italy, which offset the simple white forms of tiles and basins for a striking white on white effect.



ZUCCHETTI.





ACACIA E

An evolution in toilet technology

With the development of the new Acacia Evolution collection, Ideal Standard have introduced technological breakthroughs that not only enhance performance but also help save our precious environment.

Key highlights of the Acacia Evolution's toilet include:

- Revolutionary Double Vortex flushing system
- Reduced water consumption
- Total hygiene protection with Anti-Bacterial finish
- Proguard ceramic surface protection
- Easy clean rimless design



Ideal Standard



Double Vortex Flushing System

Unlike other toilets, the Double Vortex system flushes 100% of the water at once through two water openings positioned at the top of the bowl, creating two powerful whirlpools that flush waste away while cleaning the entire surface of the ceramic bowl leaving nothing behind.



Reduced water consumption

Despite its power, this improved flush also boasts a lower water consumption with 4 litres for full flush and only 2.6 litres of water for half flush. This water saving equates to approximately 22,776 litres of water saved in a year for a family of 4.

Calculation criterion is as follows. Average family number: four people. Average usage number of times: five times/person per day (full-flush: one time, half-flush: four times). Water savings is based on conventional Single Flush Toilets versus Double Vortex.



Total hygiene protection

Ideal Standard's anti-bacterial finish covers all essential touch points, including the push button, seat and cover, to provide an ultimate hygienic environment by effectively inhibiting the growth of bacteria.

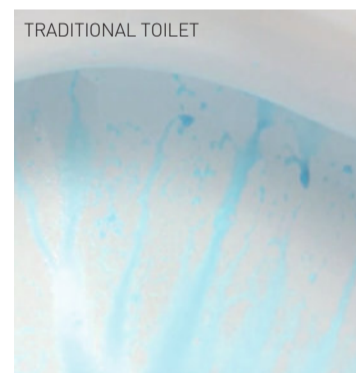

Proguard ceramic surface protection

All Acacia Evolution toilets come equipped with Proguard that inhibits the build-up of water stains making cleaning a breeze. Water stains on ceramic wares are often caused by silica. Silica, which occurs naturally in water, bonds chemically with ceramic surfaces thereby causing water stains. Proguard, which is applied to the ceramics, prevents silica in the water from adhering to the surface.

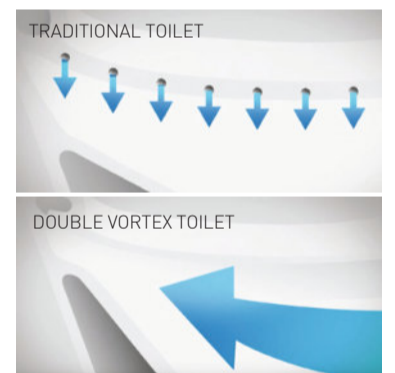
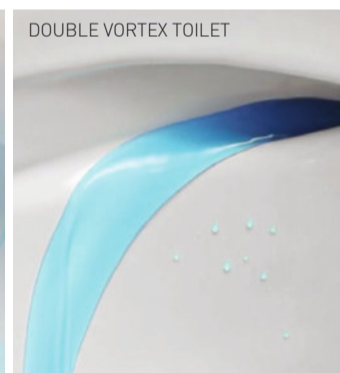

Easy Clean rimless design

The Double Vortex rimless design makes it easy to clean as no dirt can accumulate over time unlike traditional toilets that have many small rim holes that causes stains on the surface of the bowl.



Sustainable foresight

"Excellent design is no longer just about aesthetics. Today, designers require the foresight to construct sustainable living environments for future generations while catering for various lifestyle needs"

KHUMTONG JANSUWAN / CHIEF DESIGNER

The complete collection

Acacia Evolution Toilets are available in back to wall, close coupled and monoblock as well as wall and floor pan options.



Tap, tap, tap @ ROBERTSON.CO.NZ

With the ever-increasing trend of working on the run, the Robertson mobile friendly website provides a wealth of information, just a tap away!

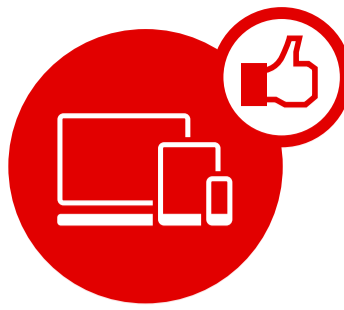

Save your product choices as you browse to 'My List' which can then be printed or emailed.

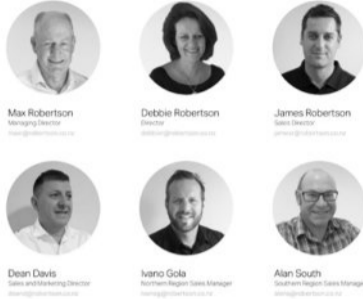
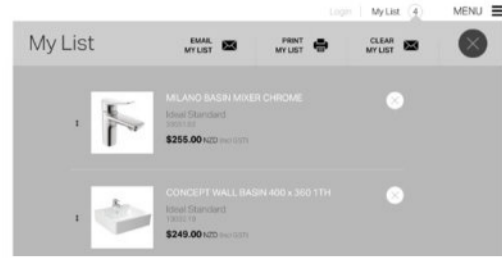

Find out about Robertson and meet our expert team on hand to help with professional and friendly advice and support.

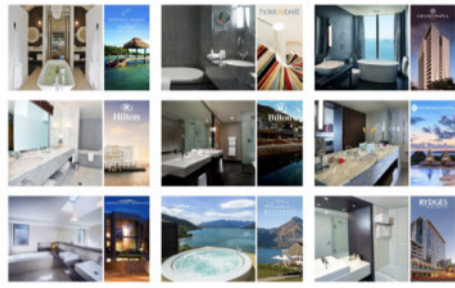

Browse the Gallery for inspiration and information on our latest project developments.



Find all our clearance products at a 'Hot Deal' price.

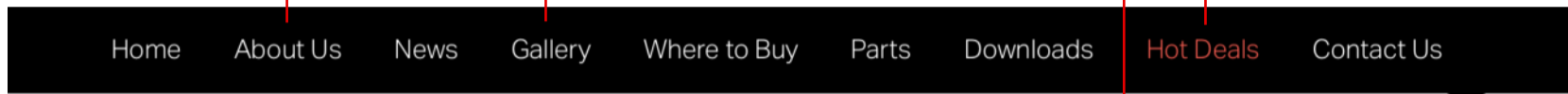

Login | My List 0 | MENU

Products Brands Keyword / Code search...

Simply start your journey by browsing through Brand or Product group to find what you are looking for, right down to all current specifications, installation information and product finishes (if applicable).

Do you have an idea of what you are looking for? Simply start typing the name of the product you are after and our suggestive search will do the rest.



Visit our **NEW** Wellington Showroom 23 Marion St



Request our latest brochures

Issue 17 of our latest IDEAS brochure is a treasure trove of innovative product and great design, while our GROHE brochure features the finest tapware from the masters of design and technology. Request your FREE copies now!

sales@robertson.co.nz



PH: +64 (0)9 573 0490
FAX: +64 (0)9 573 0495
EMAIL: sales@robertson.co.nz

AUCKLAND SHOWROOM

25 Vestey Drive, Mt Wellington
Auckland 1060
Open Monday - Friday 8.30am - 5pm
Saturday 9am - 1pm

WELLINGTON SHOWROOM

23 Marion St, Te Aro, Wellington 6011
Open Monday - Friday 8am - 5pm Closed Saturday
For a bathware consultation please make an appointment by emailing sales@robertson.co.nz

Our NEW Wellington showroom has just opened at 23 Marion St, Te Aro, in conjunction with Jacobsens. Come in and view a wide range of our products on display. If you require a bathware consultation please email sales@robertson.co.nz to make an appointment.

ROBERTSON.CO.NZ

